



ZKL GROUP

**BEARINGS
FOR RAILWAY
APPLICATIONS**





BEARINGS FOR RAILWAY APPLICATIONS



The railway industry is a promising field world-wide. ZKL therefore dedicates special attention to the bearings for rail vehicles. The product range of these bearings includes bearings for various types of drives, pumps and fans, as well as for rail vehicle axles. Traction motors for electrical locomotives and driving electrical units are a special category. ZKL is expanding its production line by the addition of compact tapered roller bearing units to be mounted on the axles of rail-borne vehicles, as well as conventional and electrically insulated bearings for traction motors. Aside from special bearings, ZKL offers additional engineering support as a part of the service offer. Concerning the deliveries of the bearings manufactured we recommend to consult these with the ZKL's professional staff.

Axle bearings

The development and manufacture of ZKL railway axle bearings meet the requirements of the EN 12080, UIC 510-1, TSI standards and European Maintenance Guide. The bearings are designed with the use of advanced designing and computing software. The verification of the parameters takes place by testing the bearings at testing stations following an internal ZKL methodology, and by applying the UIC 515-5 and EN 12082 standards.

Cylindrical roller bearings

The cylindrical roller bearings are particularly suitable for accommodate high radial loads as well as shock axial loads at high rotational speeds. The bearings feature an optimized internal design capable of intercepting dynamic forces they are subject to, in both the radial and axial directions, ensuring simultaneously an excellent greasing in all operating conditions.



The axle cylindrical roller bearings are manufactured in pairs that consist of two single-row bearings of an unequal design. The internal bearing is designed with two integral flanges on the outer ring and one integral flange on the inner ring – NJ(WJ) design. The external bearing ring incorporates two internal flanges on the outer ring and – one inner ring with non-integral flange in the form of loose flange ring – NJP (WJP) design. The bearing is positioned in order to have the non-integral flange on the external side of the bearing pair.

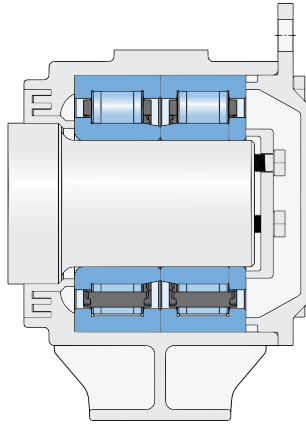

The bearings are manufactured with a massive brass cage or plastic cage (made from fibreglass reinforced PA66-GF25 polyamide). The plastic cages meet the most demanding requirements imposed on bearings for railway applications. The marking of the bearings with a plastic cage differs from those with a brass cage, by the appended "2" index number.

The ZKL bearings correspond to the design of bearings having the international marking:

WJ/WJP 120x240TNG ZKL: PLC 410-13/14.2

WJ/WJP 130x240TNG ZKL: PLC 410-33/34.2

The cylindrical roller bearings are manufactured in various versions which may differ from the basic design e.g. in the diameter of the inner ring raceway, but also in the diameter of the bearing opening.

One example of a bearing with differing inner ring raceway diameter (the "F" parameter in the table) is the WJ/WJP 130x240TNG (PLC 410-33/34.2), whose outer subassemblies and inner rings are interchangeable according to VPI-EMG. Compared to the PLC 410-15/16 type it features the same built-in dimensions, however, with a smaller inner ring raceway diameter, which results in an increased dynamic and static load carrying capacity of the bearing. Despite the same built-in dimensions the bearings are not interchangeable, except where such a change is approved in the client's documentation.

Bearings with a reduced inner ring bore diameter are used on axles with re-machined pins. Compared to the basic design the designation of such bearing differs in the numerical index at the bearing code end (e.g. the PLC 410-15.2 basic bearing design features a bore diameter of 130 mm, while the PLC 410-15.2.4 bearing has a bore diameter reduced to 129 mm). In case a bearing different from the basic design that is not listed in the table is required, please contact the technical-consultation services of ZKL.

Tapered roller bearing units

These are special double-row tapered roller bearings used for the mounting on axles of high-speed passenger and cargo rail vehicles. The bearings consist of a common outer ring, two inner rings and two rows of tapered rolls with cages made from fibreglass reinforced polyamide PA66-GF25. The bearing rings have a surface treated with zinc phosphate, which



protects the bearing from corrosion. The bearings have their axial clearance optimally adjusted and are supplied in a condition ready for direct installation. The bearing is filled with grease and its inner space is sealed with a special seal or shield that prevent the lubricant to leak from the bearing and at the same time protect the bearing against contamination. The service intervals for the bearings are determined depending on the rail vehicle operating conditions according to which the bearings are subject to servicing by the manufacturer. The assembly and disassembly of these units for railway vehicles' axles is easy, quick and safe, with the use of hydraulic equipment. The installation of the bearings is described in the assembly instructions.

The bearings correspond to the design of the bearings with international markings:

TBU (CTBU) 130x230	ZKL: PLC 810-13
TBU (CTBU) 130x210	ZKL: PLC 810-15
TBU (CTBU) 150x250	ZKL: PLC 810-25

ZKL manufactures the tapered roller bearing units in various versions for various types of designations, differing in the amount of lubricant used, the type of sealing, etc. The respective design variations differ from the basic design in the marking index which consists of a numerical symbol or a combination of numbers and letters.

Spherical roller bearings

Spherical roller bearings consist of two rows of rollers, with a common spherical raceway in the external bearing ring. This design makes it possible to have the rings mutually misaligned to compensate for some axial misalignment or shaft deflection. Thanks to their design they are suitable for carrying very heavy radial loads, but at the same time also for significant axial loads acting in both directions. These characteristics make them particularly suitable for applications where heavy loads have to be transferred. Apart from using them primarily for the mounting on axles on older types of rail vehicles they are also used e.g. in gearboxes and fan drives.



On the axles of rail vehicles are very often used the spherical roller bearing of 130 x 220 x 73 mm, in accordance with the UIC dimensional plan for the mounting on axles of rail vehicles with a bearing inner diameter of 130 mm. This bearing is marked as PLC 59-7. Aside from this also bearings of normal dimensional series according to ISO standard are being used and enlisted in the table. Spherical roller bearings in the rail vehicle axles are either used alone or as a pair with a spacing ring inserted between the bearing's inner rings.

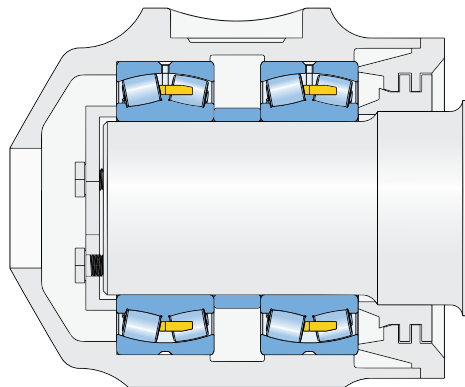

Bearings for traction motors

Bearings for traction motors are designed to meet demands for economic operation costs, high durability and reliability. The traction motor bearings are working under heavy-duty operating conditions with high loads and rotation speeds. They may consequently be manufactured with a higher degree of precision (P6, P5) and with an increased radial clearance (C3, C4). The heat treatment of the bearing rings guarantees the stability of the components' dimensions during operations at higher temperatures (S1, S2). The bearing's internal design is prepared to provide high axial load-bearing capacity during operation. The bearings are manufactured with a solid brass cage which is guided by rolling elements (M design) or with guidance on outer ring (MA design). The cage and the guiding surfaces are designed to achieve optimum lubrication and to provide a low heat generation.



The traction motor bearings are most frequently single row deep groove ball bearings used where light radial loads and high speeds are needed, or single-row cylindrical roller bearings used to support heavier radial loads. Cylindrical roller bearings are also used for bearing arrangements in which axial displacement of components is allowed to occur due to thermal expansion.

Deep groove ball bearings and cylindrical roller bearings for traction motors are delivered either in standard versions or in a version with an insulation ceramic Al_2O_3 coating which prevents the passage of electrical current through the bearing and prevents from any damage of the raceways and decomposition of the lubricant. The insulation Al_2O_3 coating is 0.15 mm thick, applied on the outer ring. The bearings insulated in such a way are capable to withstand DC voltages of up to 1000 Volts. The layer is applied by a thermal spraying onto the external surface of the outer bearing ring and satisfies the requirements of high surface hardness and

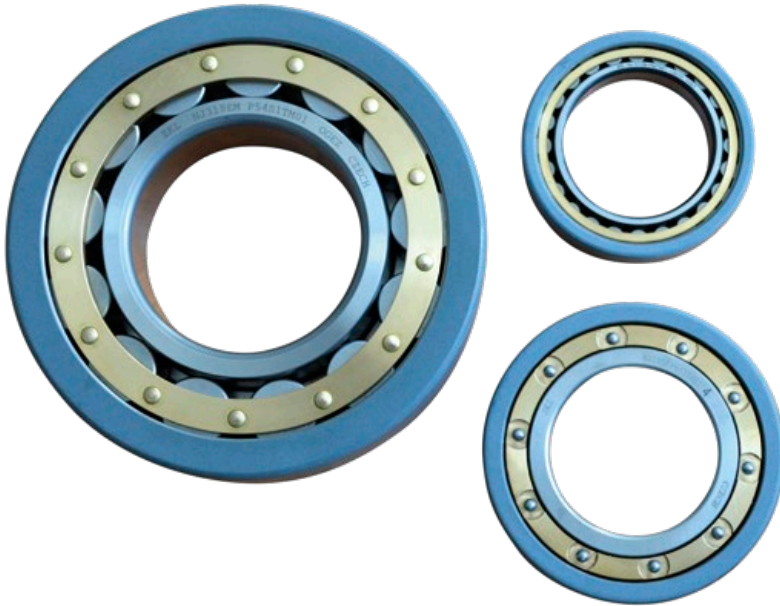

surface adhesive capacity. The bearings with insulation layer of aluminium oxide on the outer ring bear an additional marking TM01 after the basic marking code, e.g. NU1012M TM01.

The size of bearings with an insulation layer, incl. all the tolerances of the main dimensions, is the same as with those without the insulation layer. Also the tolerance on fit for bearings with an insulation layer is the same as with normal bearings without the insulation layer. Consequently, in case of necessity, a bearing without an insulation layer can be easily replaced with a bearing having the insulation layer.

Basic guidelines for the use of bearings

Transport, handling and storage of bearings

During transport, handling and storage the bearings are not allowed to be exposed to vibrations and shocks that might cause a damage to the rolling surfaces. The bearings have to be stored in the manufacturer's original packaging, in storage areas featuring a stable temperature range within 20 ± 5 °C and with a relative humidity of up to 60 %. Breaking the package or changing the storage conditions causes a significant reduction of the corrosion resistance of the bearings, combined with the risk of contamination by dirt.

Installation of the bearings

The bearings may be installed by trained persons only. Before starting the assembly steps the installer is obliged to make himself/herself familiar with the basic assembly instructions. Check the condition of the bearings and verify whether their marking corresponds to agreed requirements or engineering acceptance conditions.

It is advisable to heat the bearing rings to facilitate the insertion of the axles into the inner ring. The heating can be done using induction heaters, heating ovens or by heating the bearing in an oil bath. Usually the bearing is heat up to a temperature higher by 80 °C than the one of the shaft. However, the bearing temperature during the heating process is not allowed to exceed 120 °C. The hot mounting may be applied only to open bearings (cylindrical roller bearings, spherical roller bearings and deep groove ball bearings). Sealed tapered roller bearing units with lubricant grease filling from the manufacturer have always to be installed in cold mounting.

Contact our Technical support for more information or assistance. Our team can assist you with the assembly and disassembly of standard and special bearings anywhere in the world. On request, we can also prepare assembly and maintenance manuals or organise theoretical and practical trainings.

Lubrication of the bearings

Open type of bearings (cylindrical roller bearings, spherical roller bearings and deep groove ball bearings) are greased immediately after their installation. The bearings shall be greased with grease suitable for railway applications. The type of grease is approved and may be recommended by the bearing manufacturer. Tapered roller bearing units are sealed and greased in the course of their manufacture and, consequently, they are not re-greased in any way whatsoever after the installation.

Quality policy

In accordance with the company's strategy and the requirements of ISO 9001, ISO 14001, ISO 45001 and ISO/TS 22163, the management of the ZKL Group and its subsidiaries undertake to meet and exceed the requirements and expectations of our customers, to protect not only the health of our employees but also with the responsibility of a proper manager not to stop improving, protecting the environment and health so that we pass on the legacy of the ZKL bearings tradition to future generations.

Certificates

ISO 9001:2015, ISO 14001:2015, ISO 45001:2018, ISO/TS 22163:2017, TSI



Single row ball bearings for traction motors $d = 65$ to 150 mm

Dimensions				Basic Load Rating		Fatigue Load Limit	Limiting Speed for Lubrication with		Bearing Designation
d	D	B	r_s	Dynamic	Static		Grease	Oil	
mm				kN		kN	min^{-1}		Standard
65	100	18	1.1	30.5	25.1	1.14	6 300	7 500	6013MA
	120	23	1.5	57.2	40	1.89	5 300	6 300	6213MA
70	110	20	1.1	38	31	1.41	5 600	6 700	6014MA
	125	24	1.5	62	43.8	2.02	5 300	6 300	6214MA
75	115	20	1.1	39.8	33.2	1.55	5 300	6 300	6015MA
	130	25	1.5	66.2	49.3	2.21	5 000	6 000	6215MA
80	125	22	1.1	47.5	39.8	1.79	5 000	6 000	6016MA
	140	26	2	72.2	53.1	2.3	4 700	5 600	6216MA
	170	37	2.1	123	86.2	3.51	4 000	4 700	6316MA
85	150	28	2	83.3	63.7	2.67	4 200	5 000	6217MA
	180	41	3	133	96.1	3.79	3 800	4 500	6317MA
90	160	30	2	96.2	70.8	2.88	4 000	4 700	6218MA
	190	43	3	144	108	4.15	3 500	4 200	6318MA
95	170	32	2.1	108	81	3.20	3 800	4 500	6219MA
	200	45	3	152	117	4.39	3 300	4 000	6319MA
100	180	34	2.1	123	92.6	3.56	3 500	4 200	6220MA
	215	47	3	174	141	5.11	3 200	3 800	6320MA
110	200	38	2.1	144	117	4.27	3 200	3 800	6222MA
	240	50	3	203	180	6.18	2 600	3 200	6322MA
120	215	40	2.1	144	117	4.11	3 000	3 500	6224MA
	260	55	3	208	186	6.13	2 500	3 000	6324MA
130	230	40	3	156	132	4.47	2 600	3 100	6226MA
	280	58	4	229	216	6.86	2 350	2 800	6326MA
140	250	42	3	166	150	4.88	2 500	3 000	6228MA
	300	62	4	251	245	7.51	2 350	2 800	6328MA
150	270	45	3	190	181	5.68	2 200	2 700	6230MA
	320	65	4	276	285	8.45	2 000	2 400	6330MA

Bearing Designation	Abutment and Fillet Dimensions			Weight
	d_a min	D_a max	r_a max	
Electrically insulated	mm			kg
6013MA TM01	70	93	1	0.44
6213MA TM01	72	111	1.5	1
6014MA TM01	75	103	1	0.61
6214MA TM01	77	116	1.5	1.07
6015MA TM01	80	108	1	0.65
6215MA TM01	82	122	1.5	1.18
6016MA TM01	85	118	1	0.87
6216MA TM01	90	130	2	1.4
6316MA TM01	91	158	2	3.63
6217MA TM01	95	140	2	1.8
6317MA TM01	98	166	2.5	4.2
6218MA TM01	100	150	2	2.16
6318MA TM01	103	176	2.5	4.95
6219MA TM01	107	158	2	2.6
6319MA TM01	109	186	2.5	5.72
6220MA TM01	112	169	2	3.13
6320MA TM01	113	201	2.5	7.07
6222MA TM01	122	188	2	4.37
6322MA TM01	123	227	2.5	9.58
6224MA TM01	132	203	2	5.15
6324MA TM01	134	246	2.5	12.5
6226MA TM01	144	216	2.5	5.75
6326MA TM01	147	263	3	15.2
6228MA TM01	154	236	2.5	7.56
6328MA TM01	157	283	3	21.8
6230MA TM01	164	256	2.5	9.85
6330MA TM01	167	303	3	24

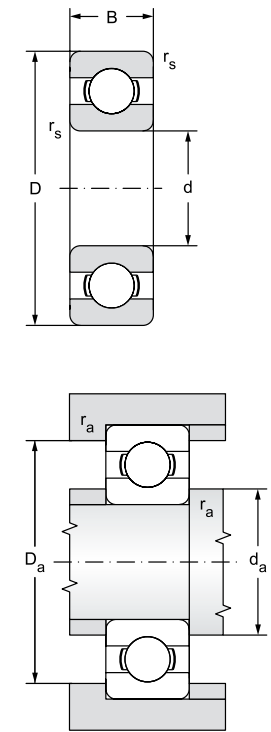

Single row cylindrical roller bearings for traction motors d = 35 to 150 mm

Dimensions							Basic Load Rating		Fatigue Load Limit	Limiting Speed for Lubrication with	
							Dynamic	Static			
d	D	B	r _s	r _{1s}	F	s ¹⁾	C _r	C _{or}	P _u	Grease	Oil
mm							kN		kN	min ⁻¹	
35	62	14	1	0.6	42	1	22.6	23.2	2.83	11 000	13 000
40	68	15	1	0.6	47	1	27.3	29	3.54	10 000	12 000
45	75	16	1	0.6	52.5	1	32.5	35.5	4.33	9 000	11 000
50	80	16	1	0.6	57.5	1.5	32	36	4.39	8 000	10 000
55	90	18	1.1	1	64.5	1.5	37.5	44	5.37	7 500	9 000
60	95	18	1.1	1	69.5	2	41	51	6.22	6 700	8 500
65	100	18	1.1	1	74.5	2	44	57	6.95	6 300	8 000
70	110	20	1.1	1	80	2	59	71	8.66	6 000	7 100
	125	24	1.5	1.5	83.5	1.2	139	141	17.2	5 600	6 700
	125	24	1.5	1.5	83.5	1.2	139	141	17.2	5 600	6 700
	150	35	2.1	2.1	89	1.8	239	226	26.8	4 200	5 000
	150	35	2.1	2.1	89	1.8	239	226	26.8	4 200	5 000
75	115	20	1.1	1	85	2.5	60	74.5	9.23	5 600	6 700
	130	25	1.5	1.5	88.5	1.2	151	161	19.5	4 700	5 600
	130	25	1.5	1.5	88.5	1.2	151	161	19.5	4 700	5 600
	160	37	2.1	2.1	95	1.8	280	268	31.1	3 800	4 500
	160	37	2.1	2.1	95	1.8	280	268	31.1	3 800	4 500
80	125	22	1.1	1	91.5	2.5	72.5	90.5	11	5 300	6 300
	140	26	2	2	95.3	1.4	162	171	20.3	4 500	5 300
	140	26	2	2	95.3	1.4	162	171	20.3	4 500	5 300
	170	39	2.1	2.1	101	2.1	302	291	33.2	3 500	4 200
	170	39	2.1	2.1	101	2.1	302	291	33.2	3 500	4 200
85	150	28	2	2	100.5	1.5	192	201	23.4	4 200	5 000
	150	28	2	2	100.5	1.5	192	201	23.4	4 200	5 000
	180	41	3	3	108	2.3	343	341	38.2	3 300	4 000
	180	41	3	3	108	2.3	343	341	38.2	3 300	4 000
90	160	30	2	2	107	1.8	213	225	25.7	4 000	4 700
	160	30	2	2	107	1.8	213	225	25.7	4 000	4 700
	190	43	3	3	113.5	2.9	368	360	39.7	3 200	3 800
	190	43	3	3	113.5	2.9	368	360	39.7	3 200	3 800

¹⁾ Permissible axial displacement
^{**} Bearing ZKL NEW FORCE

Bearing Designation		Abutment and Fillet Dimensions							Weight
		d	d _a	d _a	d _b	D _a	r _a	r _b	
Standard	Electrically insulated		min	max	min	max	max	max	~
		mm							kg
NU1007M	NU1007M TM01	35	38,2	41	44	56	1	0.6	0.18
NU1008M	NU1008M TM01	40	43,2	45	49	63.4	1	0.6	0.23
NU1009M	NU1009M TM01	45	48,2	51	54	70.4	1	0.6	0.28
NU1010M	NU1010M TM01	50	53,2	56	60	75.4	1	0.6	0.3
NU1011M	NU1011M TM01	55	59,6	63	67	84	1	1	0.45
NU1012M	NU1012M TM01	60	64,6	68	72	89	1	1	0.48
NU1013M	NU1013M TM01	65	69,6	72	77	94	1	1	0.52
NU1014M	NU1014M TM01	70	74,6	78	82	104	1	1	0.7
NU214EM**	NU214EM TM01**		77	82	86	117	1.5	1.5	1.15
NJ214EM**	NJ214EM TM01**		77	82	86	117	1.5	1.5	1.15
NU314EM**	NU314EM TM01**		81	85	92	139	2	2	2.7
NJ314EM**	NJ314EM TM01**		81	85	92	139	2	2	2.85
NU1015M	NU1015M TM01	75	79,6	83	87	109	1	1	0.74
NU215EM**	NU215EM TM01**		82	85	90	122	1.5	1.5	1.25
NJ215EM**	NJ215EM TM01**		82	85	90	122	1.5	1.5	1.3
NU315EM**	NU315EM TM01**		86	93	97	149	2	2	3.3
NJ315EM**	NJ315EM TM01**		86	93	97	149	2	2	3.3
NU1016M	NU1016M TM01	80	86	90	94	119	1	1	1
NU216EM**	NU216EM TM01**		90	92	97	131	2	2	1.55
NJ216EM**	NJ216EM TM01**		90	92	97	131	2	2	1.6
NU316EM**	NU316EM TM01**		99	97	105	159	2	2	3.9
NJ316EM**	NJ316EM TM01**		99	97	105	159	2	2	4
NU217EM**	NU217EM TM01**	85	95	99	104	141	2	2	1.9
NJ217EM**	NJ217EM TM01**		95	99	104	141	2	2	1.9
NU317EM**	NU317EM TM01**		98	103	110	166	2.5	2.5	4.6
NJ317EM**	NJ317EM TM01**		98	103	110	166	2.5	2.5	4.75
NU218EM**	NU218EM TM01**	90	100	105	109	151	2	2	2.3
NJ218EM**	NJ218EM TM01**		100	105	109	151	2	2	2.4
NU318EM**	NU318EM TM01**		103	110	117	177	2.5	2.5	5.25
NJ318EM**	NJ318EM TM01**		103	110	117	177	2.5	2.5	5.4

Single row cylindrical roller bearings for traction motors $d = 35$ to 150 mm

Dimensions							Basic Load Rating		Fatigue Load Limit	Limiting Speed for Lubrication with	
							Dynamic	Static			
d	D	B	r_s	r_{1s}	F	$s^{1)}$	C_r	C_{or}	P_u	Grease	Oil
mm							kN		kN	min^{-1}	
95	170	32	2.1	2.1	112.5	1.7	255	270	30.3	3 800	4 500
	170	32	2.1	2.1	112.5	1.7	255	270	30.3	3 800	4 500
	200	45	3	3	121.5	2.9	393	389	42.2	3 200	3 800
	200	45	3	3	121.5	2.9	393	389	42.2	3 200	3 800
100	180	34	2.1	2.1	119	1.7	288	311	34.3	3 500	4 200
	180	34	2.1	2.1	119	1.7	288	311	34.3	3 500	4 200
	215	47	3	3	127.5	2.9	452	445	47.4	2 800	3 300
	215	47	3	3	127.5	2.9	452	445	47.4	2 800	3 300
110	240	50	3	3	143	3	532	542	55.9	2 500	3 000
	240	50	3	3	143	3	532	542	55.9	2 500	3 000
120	260	55	3	3	154	3.7	615	621	62.5	2 400	2 800
	260	55	3	3	154	3.7	615	621	62.5	2 400	2 800
130	280	58	4	4	167	3.7	718	747	73.4	2 200	2 400
	280	58	4	4	167	3.7	718	747	73.4	2 200	2 400
140	300	62	4	4	180	3.7	788	831	80	2 000	2 400
	300	62	4	4	180	3.7	788	831	80	2 000	2 400
150	320	65	4	4	193	4	888	944	89.1	1 900	2 200
	320	65	4	4	193	4	888	944	89.1	1 900	2 200

¹⁾ Permissible axial displacement
 ** Bearing ZKL NEW FORCE

Bearing Designation		Abutment and Fillet Dimensions						Weight	
		d	d_a	d_a	d_b	D_a	r_a		r_b
Standard	Electrically insulated	min	max	min	max	max	max	~	
		mm						kg	
NU219EM**	NU219EM TM01**	95	107	111	116	159	2	2	2.8
NJ219EM**	NJ219EM TM01**		107	111	116	159	2	2	2.85
NU319EM**	NU319EM TM01**		109	119	124	187	2.5	2.5	6.2
NJ319EM**	NJ319EM TM01**		109	119	124	187	2.5	2.5	6.25
NU220EM**	NU220EM TM01**	100	112	117	122	169	2	2	3.4
NJ220EM**	NJ220EM TM01**		112	117	122	169	2	2	3.5
NU320EM**	NU320EM TM01**		113	125	132	202	2	2	7.45
NJ320EM**	NJ320EM TM01**		113	125	132	202	2	2	7.65
NU322EM**	NU322EM TM01**	110	124	135	145	227	2.5	2.5	10.3
NJ322EM**	NJ322EM TM01**		124	135	145	227	2.5	2.5	10.5
NU324EM**	NU324EM TM01**	120	134	145	156	247	2.5	2.5	13
NJ324EM**	NJ324EM TM01**		134	145	156	247	2.5	2.5	13.3
NU326EM**	NU326EM TM01**	130	148	155	169	263	3	3	16.1
NJ326EM**	NJ326EM TM01**		148	155	169	263	3	3	16.5
NU328EM**	NU328EM TM01**	140	158	166	182	283	3	3	22
NJ328EM**	NJ328EM TM01**		158	166	182	283	3	3	22.5
NU330EM**	NU330EM TM01**	150	168	185	195	303	3	3	26.3
NJ330EM**	NJ330EM TM01**		168	185	195	303	3	3	27



NJ

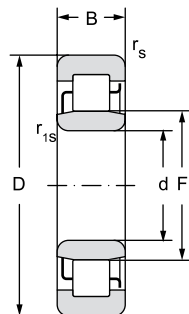

NU

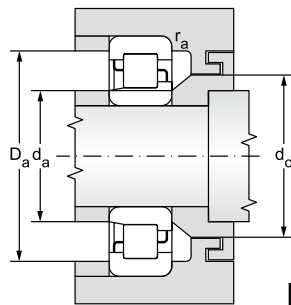

NJ

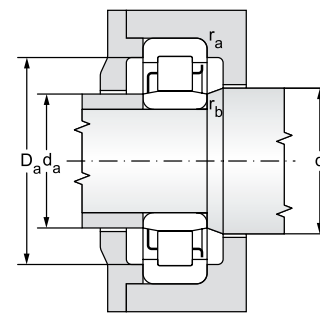

NU

Special single row cylindrical roller bearings for railway vehicle axles

Dimensions								Basic Load Rating	
d	D	B	r _s min	r _{is} min	d ₁	d ₂	F	Dynamic C _r	Static C _{or}
mm								kN	
100	180	60	2,1	2,1	127,3	-	119	360	490
100	180	60	2,1	2,1	-	127,3	119	360	490
110	215	73	4	4	147	-	135,5	460	650
110	215	73	4	4	-	147	135,5	460	650
118	240	80	3	7,5	160,8	-	150	553	742
118	240	80	3	7,5	-	160,8	150	553	742
119	240	80	3	7,5	160,8	-	150	553	742
119	240	80	3	7,5	-	160,8	150	553	742
119,3	240	80	3	7,5	160,8	-	150	553	742
119,3	240	80	3	7,5	-	160,8	150	553	742
120	200	62	2,1	2,1	148	-	140	371	565
120	200	62	2,1	2,1	-	148	140	371	565
120	215	73	3	2,1	150,8	-	140,5	520	730
120	215	73	3	2,1	-	150,8	140,5	520	730
120	240	80	3	7,5	160,8	-	150	553	742
120	240	80	3	7,5	-	160,8	150	553	742
120	240	80	3	7,5	160,8	-	150	553	742
120	240	80	3	7,5	-	160,8	150	553	742
127	240	80	3	7,5	170,5	-	159	517	752
127	240	80	3	7,5	-	170,5	159	517	752
128	240	80	3	7,5	170,5	-	159	517	752
128	240	80	3	7,5	-	170,5	159	517	752
129	240	80	3	7,5	170,5	-	159	517	752
129	240	80	3	7,5	-	170,5	159	517	752
128	240	80	3	7,5	170,5	-	157	540	775
128	240	80	3	7,5	-	170,5	157	540	775
129	240	80	3	7,5	170,5	-	157	540	775
129	240	80	3	7,5	-	170,5	157	540	775
129,3	240	80	3	7,5	170,5	-	157	540	775
129,3	240	80	3	7,5	-	170,5	157	540	775
129,97	240	80	3	7,5	170,5	-	157	540	775
129,97	240	80	3	7,5	-	170,5	157	540	775
130	240,03	80	3	7,5	170,5	-	157	540	775
130	240,03	80	3	7,5	-	170,5	157	540	775
130	220	73	3	3	160,2	-	151	500	760
130	220	73	3	3	-	160,2	151	500	760
130	240	80	3	7,5	170,5	-	159	517	752
130	240	80	3	7,5	-	170,5	159	517	752
130	240	80	3	7,5	170,5	-	159	517	752

d = 100 to 160 mm

Bearing Designation	Weight
	kg
PLC 410-57	6,7
PLC 410-58	6,7
PLC 410-60	12,5
PLC 410-61	12,5
WJ 118x240TNG (PLC 410-13.2.3)	16,2
WJP 118x240TNG (PLC 410-14.2.3)	16,2
WJ 119x240TNG (PLC 410-13.2.4)	16,1
WJP 119x240TNG (PLC 410-14.2.4)	16,1
WJ 119.3x240TNG (PLC 410-13.2.5)	16
WJP 119.3x240TNG (PLC 410-14.2.5)	16
PLC 49-8	8,27
PLC 49-9	8,27
PLC 410-53.2 ¹⁾	10,6
PLC 410-54.2 ¹⁾	10,6
PLC 410-13	17,4
PLC 410-14	17,4
WJ 120x240TNG (PLC 410-13.2)	16
WJP 120x240TNG (PLC 410-14.2)	16
PLC 410-15.2.5	15,6
PLC 410-16.2.5	15,6
PLC 410-15.2.3	15,4
PLC 410-16.2.3	15,4
PLC 410-15.2.4	15,3
PLC 410-16.2.4	15,3
WJ 128x240TNG (PLC 410-33.2.3)	15,6
WJP 128x240TNG (PLC 410-34.2.3)	15,6
WJ 129x240TNG (PLC 410-33.2.4)	15,4
WJP 129x240TNG (PLC 410-34.2.4)	15,5
WJ 129.3x240TNG (PLC 410-33.2.9)	15,4
WJP 129.3x240TNG (PLC 410-34.2.9)	15,4
WJ 129.97x240TNG (PLC 410-33.2.10)	15,3
WJP 129.97x240TNG (PLC 410-34.2.10)	15,4
WJ 130x240.03TNG (PLC 410-33.2.1)	15,3
WJP 130x240.03TNG (PLC 410-34.2.1)	15,4
PLC 410-65.2	10
PLC 410-66.2	10
PLC 410-15	16,5
PLC 410-16	16,5
PLC 410-15.2	15,2

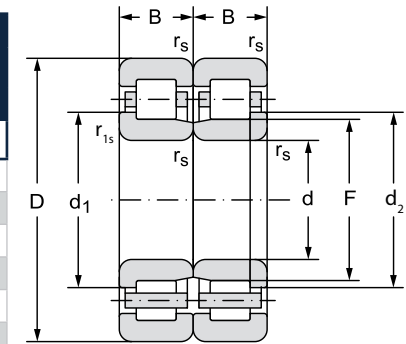

Continuation of table from page 16-17

130	240	80	3	7,5	-	170,5	159	517	752
130	240	80	3	7,5	170,5	-	157	540	775
130	240	80	3	7,5	-	170,5	157	540	775
130	250	80	3	3	172	-	160	590	800
130	250	80	3	3	-	172	160	590	800
130	250	80	3	3	172	-	160	590	800
130	250	80	3	3	-	172	160	590	800
160	300	84	4	4	208,7	-	192	888	1 250
160	300	84	4	4	-	208,7	192	888	1 250

PLC 410-16.2	15,2
PLC 410-33.2	15,3
PLC 410-34.2	15,3
PLC 410-17	18,5
PLC 410-18	18,5
PLC 410-17.2	17
PLC 410-18.2	17
PLC 411-10	28,1
PLC 411-12	28,1

¹⁾ Shield bearing with metal covers filled with grease

Depends on the operating conditions of the vehicle.
For more information, contact Technical Support at support@zkl.cz.

Double row spherical roller bearings for railway vehicle axles

d	D	Dimensions				Basic Load Rating		Bearing Designation	Limiting Speed for Lubrication with Grease
		B	r _s	a	b	Dynamic	Static		
		mm				C _r	C _{or}		
100	180	60.3	2.1	4.5	8.3	512	667	23220EW33MH**	1 700
110	200	69.8	2.1	4.5	8.3	645	867	23222EW33MH**	1 600
120	215	76	2.1	4.5	8.3	750	1020	23224EW33MH**	1 500
120	215	58	2.1	4.5	8.3	608	775	22224EW33MH**	1 900
130	220	73	3	6	11.1	570	1 080	PLC 59-7 ¹⁾	1 400
130	230	80	3	4.5	8.3	828	1 180	23226EW33MH**	1 300
130	280	93	4	7.5	13.9	1 180	1 380	22326EW33MH**	1 300
140	210	53	2	4.5	8.3	511	781	23028EW33MH**	1 800
140	250	68	3	6	11.1	822	1 080	22228EW33MH**	1 700
170	310	110	4	7.5	13.9	1 470	2 040	23234EW33MH**	950
190	290	75	2.1	7.5	13.9	962	1 510	23038EW33MH**	1 300
190	340	120	4	9	16.7	1 730	2 530	23238EW33MH**	850

¹⁾ Double row spherical roller bearing according to UIC dimensional plan for railway vehicle axles with the pivot 130 mm

** Bearing ZKL NEW FORCE

Tapered bearing unit TBU

d	D	Dimensions		Basic Load Rating		Bearing Designation	Equivalent
		C	B	Dynamic	Static		
		mm		C _r	C _{or}		
130	210	132	148	658	1 260	PLC 810-15	CTBU 130x210
130	230	160	176.35	913	1 620	PLC 810-13	CTBU 130x230
150	250	160	154.5	1 060	2 100	PLC 810-14	CTBU 150x250
150	250	160	164	1 170	2 150	PLC 810-25	CTBU 150x250

d = 100 to 190 mm

Abutment and Fillet Dimensions			Weight	Factors			
d _a	D _a	r _a		e	Y ₁	Y ₂	Y ₀
min	max	max		kg			
112	168	2	6.67	0.31	2.2	3.2	2.1
122	188	2	9.67	0.33	2.1	3.1	2
132	203	2	12.1	0.33	2	3	2
132	203	2	9.07	0.25	2.7	3.9	2.5
144	206	2.5	10.1	0.34	2	2.9	1.9
144	216	2.5	14.2	0.33	2.1	3.1	2
148	262	3	27.4	0.33	2.1	3.1	2
150	200	2	6.58	0.22	3	4.5	3
154	236	2.5	14.3	0.25	2.7	3.9	2.5
188	292	3	36	0.34	2	3	2
202	278	2	17.6	0.23	2.9	4.4	2.9
208	322	3	46.5	0.33	2	3	2

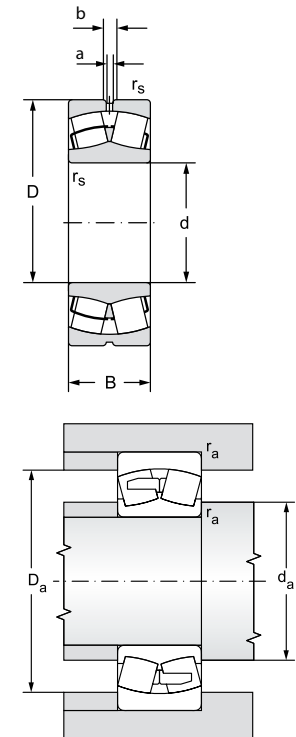

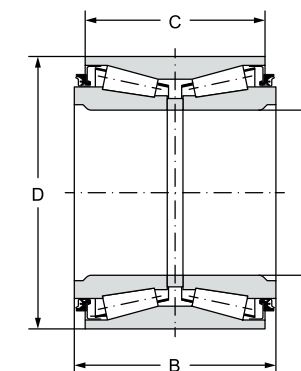

Weight
kg
18
31.7
35
33.5



ZKL Bearings CZ, a.s.

Líšeňská 45, Brno,
Czech Republic, Europe

 +420 544 135 103

 info@zkl.cz

Technical support

 +420 544 135 412

 support@zkl.cz

® ZKL and New Force are registered trade marks of the ZKL Group.

The contents of this publication are the copyrights of the publisher and may not be reproduced (even extracts) unless prior written permission granted.

The accuracy of the data contained in this publication has been checked with the utmost care, but we are not responsible for any damages, whether direct, indirect or consequential, which would be caused by the use of the information contained herein.

ZKL EDITION 8/24/EN

